

Instructions

Tuscany Column Molds

Included in Tuscany Column Complete Mold Set: Two Piece Crown/
Base Mold, **Hardware** and **2 Piece Tube Mold with Hardware** Including
Instructions (molds may also be purchased individually)

IMPORTANT Please Read

Artistic Home & Garden Co.
will not be held responsible
for any installation.

All installations are the
responsibility of the installer.

General preparations

Additional Items Needed:

- Pre mixed concrete—see *qty to right*)
- Mixing tool - small shovel or garden hoe
- Large mixing tub or wheelbarrow
- Lubricant or a mold release
- 120 lbs apx. concrete needed for 1 capital or base
- 95 lbs apx. concrete needed for each 12" column segment
- Always prepare the molds using a lubricant or a mold release (*any concrete release agent, cooking spray or WD40—use sparingly*)
- Mix the concrete adding water and mixing until you achieve a lumpy but not dry/crumby or runny consistency
- **Optional items: concrete colorants to add to mix, concrete paints or stains to apply afterward**

Casting With the Capital / Base Molds

- Place the mold assembly upright and level
- Fill the molds 4 inches at a time and bounce and tap in between to spread the concrete inside the mold and to drive out all the air bubbles.
- You can create a cavity in the casting by inserting an item like a 2 gal. **bucket** which will make the casting lighter (be sure **to remove the insert after 2 hours** before concrete is fully cured and solid—twist & pull)
- Place the molds in a dry place out of direct sun for 24 to 48 hours.
- Once concrete is set, remove the bolts, tilt the mold on the joint (rib) and remove casting onto wood blocks (pull and lift on the end of the mold)
- Brush or gently scrape away any excess concrete developed at the seam.
- The concrete will continue to set up so be gentle with handling until for at least 5 days.
- Clean the mold immediately after use and store the molds out of the sun

Column crown /base



Casting the Round Column Segments



- Bolt tube halves together, do not over tighten
- Place on a piece of plastic or cardboard on level surface
- You may create hollow segments by placing PVC tube or similar in center as long as the thickness of column is at least 5 Inches thick
- Apply mold release to all parts including plastic or cardboard base/inserts
- See reverse side about using optional fluted insert
- Fill with concrete 4 inches at a time, stopping in between to tap sides to spread concrete and to remove air bubbles
- Fill to the top of the mold and scrape top to make it even
- Allow to set up at least 24 hours
- Remove hardware and pull mold gently from your casting
- Brush or scrape excess concrete around seam if necessary
- Allow to set up for at least 10 days before stacking
- Create as many pieces as you need for desired height
- Many people prefer the natural texture of the concrete columns, but you may create a smooth finish if you prefer by mixing a small batch of mortar (sand and cement, with water to mix) to apply with a damp sponge over the surface of the column filling holes



Using Optional Tuscany Fluted Insert

- Tuscany Fluted Insert is a flat piece that wraps to fit perfectly inside of the Tuscany Tube mold
- Lubricate **raised flute side** of mold and fit inside column tube
- Follow instructions for filling the mold



Tuscany Fluted Insert has rounded flutes at both ends. If you prefer continuous flutes on your columns you will need to make adjustments.

- Most people use fluted insert as it is with rounded flutes at each end
- If you prefer a continuous fluted concrete column it is necessary to purchase a second fluted insert so you can cut both fluted ends of the mold as well as one end of the first fluted mold piece
- Another method is to cut the rounded flutes off of your finished concrete column using a **diamond tip concrete blade** (be sure to measure and mark the area to be cut on either piece)
- Some customers use the fluted insert at just the top or bottom of mold

Installing the Column

- A completed concrete column is very heavy and requires a concrete foundation at least 6 inches below the frost line in your area to avoid dangerous settling and tilting of your column
- Columns need to be mortared in place starting with the base and mortaring each segment together—**always keeping the structure level and plumb**
- For added security place a rebar in the center (if you have created a hollow center) and fill the cavity with concrete after stacking
- Remember to **be careful when lifting and handling any heavy item** - you will need help in stacking your column sections
- You can leave your column the natural concrete color or apply concrete paints or stains

Instructions For Creating Column Segments to Fit Around A Structural Post Use the Process Below for the Crown/Base Mold Also

- Column tube segments are formed by using the 2 half columns in the open face position
- This will allow you to create two half segments the 2 halves can be mortared around a existing 6x6 post
- Use wood or a foam filler block with tapered sides to create the hollow section you need to fit around your post
- Refer to drawing for detail
- Allow to set up in molds for at least 24 hours
- Use mortar to attach columns pieces around posts
- Clean seams of pieces with a damp sponge

This set up designed to create 2 half column segment to go around existing post

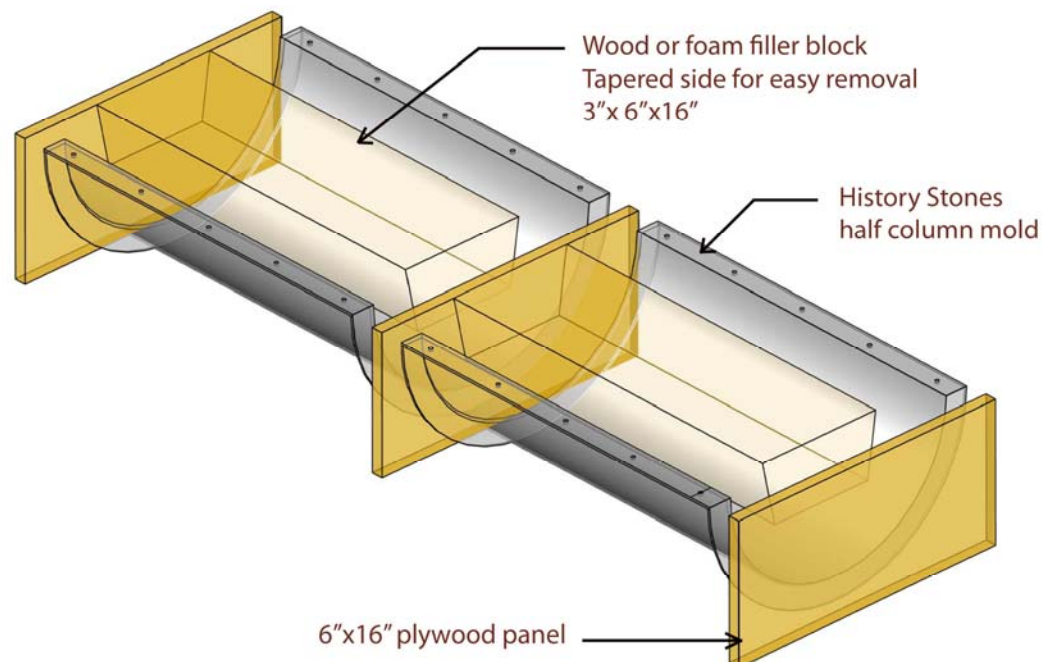

Specifications For Each Cast Concrete Piece

Measurements & Weight

- Column Base/Crown Cast Concrete Piece - 18 In. x 18 In. x 14 In., weight apx. 120 lbs.
- Each center column section Cast Concrete Piece - 10-3/4 In. diameter x 16 In. tall, weight apx. 95 lbs
- Fluted Insert Mold—11 In. long x 16" tall (wraps to fit perfectly inside column tube mold)

Mold Material

- Column Base/Crown—ABS injection molded plastic, heavy duty
- Column Tube Mold—.125 ABS plastic
- Fluted Insert—.030 ABS plastic (flexible)

